

The background of the cover is a deep red color. Overlaid on this are several technical drawings in a light, semi-transparent white. The drawings include cross-sections and elevations of tiled stoves, with labels such as 'Fig. 1.', 'Fig. 2.', 'Fig. 3.', and 'Tab III'. A large, semi-transparent white circular graphic is centered on the page, partially overlapping the drawings. The text is overlaid on a white horizontal band that spans the width of the page.

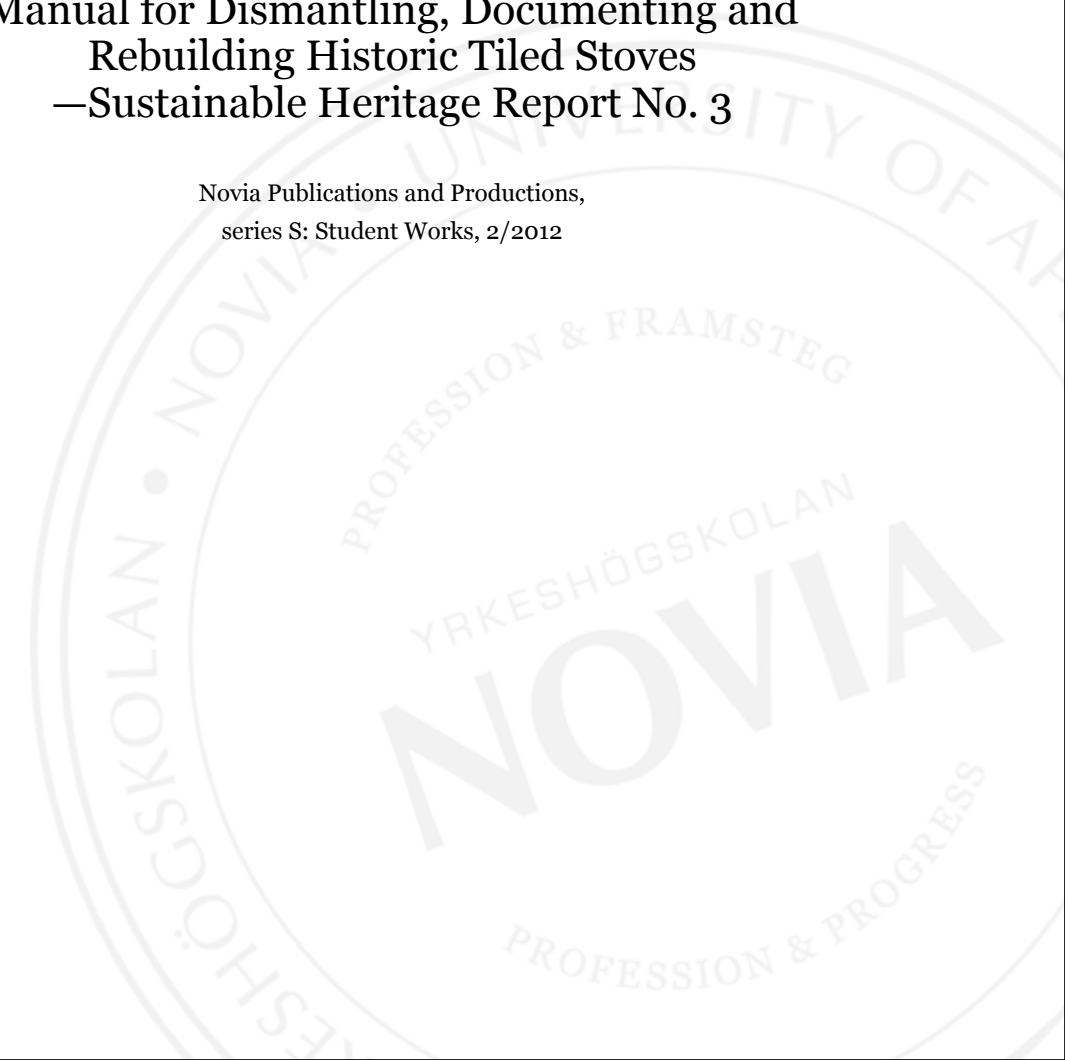
# Manual for Dismantling, Documenting and Rebuilding Historic Tiled Stoves

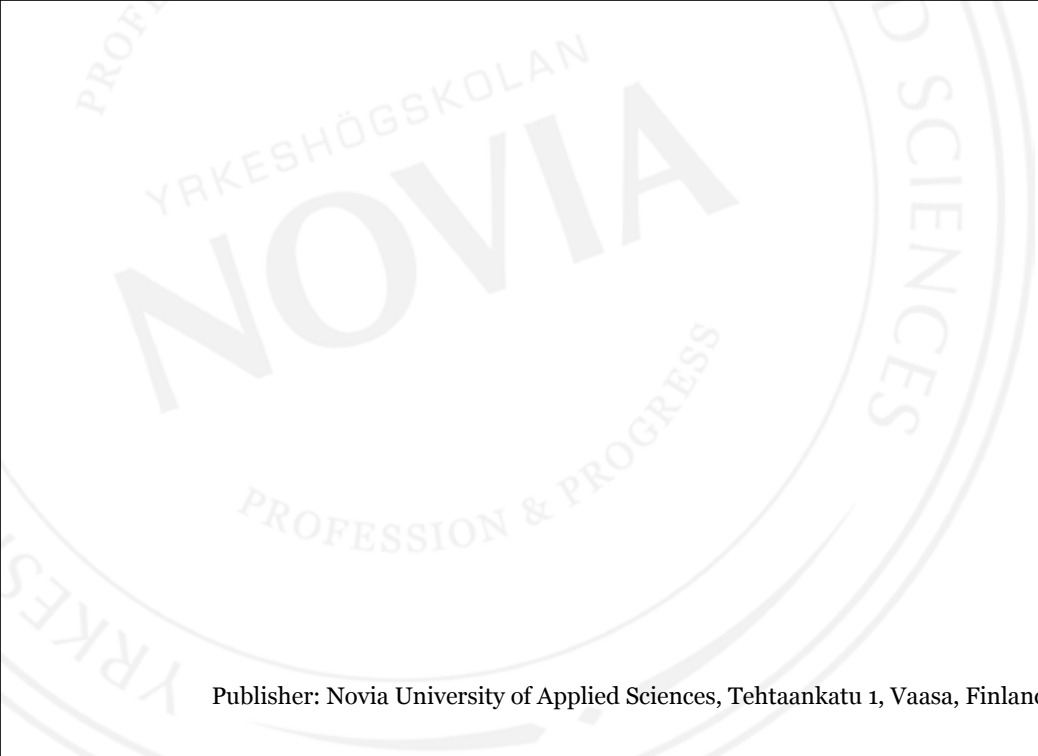
**—Sustainable Heritage Report No. 3**

**Kirsti Horn, editor**

Manual for Dismantling, Documenting and  
Rebuilding Historic Tiled Stoves  
—Sustainable Heritage Report No. 3

Novia Publications and Productions,  
series S: Student Works, 2/2012





Publisher: Novia University of Applied Sciences, Tehtaankatu 1, Vaasa, Finland

© 2012 Kirsti Horn (editor), and Novia University of Applied Sciences

© Photographs and drawings: Fredrik Berg, Emelie Jansson, Simon Jäkälä,  
Lisa Johansson, Jonas Gestranus, Tony Hagelberg, Tommy Helenius, Max Laserna,  
Isak Lind, Per Lindqvist, Emil Lindström, Thomas Lindroos, Maja Lofteskog,  
Matias Loskin, Niklas Martis, Andres Muts, Frida Nordström, Anton Öhberg,  
Kristiina Piirisild, Elin Sahlin, Sille Siidirätsep, Maria Silla, Anders Sjöström,  
Felix Thörnfeldt, Kaarel Truu, Pille Vilgota, Dennis Wilén

Layout: Michael Diedrichs

Manual for Dismantling, Documenting and Rebuilding Historic Tiled Stoves;

Sustainable Heritage Report No. 3 / Kirsti Horn (ed.)

– Vaasa: Novia University of Applied Sciences, 2012.

Novia Publications and Productions, series S: Student Works, 2/2012.

ISSN: 1799-4209 (Online)

ISBN (Online): 978-952-5839-43-2

## Manual for Dismantling, Documenting and Rebuilding Historic Tiled Stoves —Sustainable Heritage Report No. 3

Kirsti Horn, editor

A joint project between Gotland University, Estonian Academy of Arts  
and Novia University of Applied Sciences.



## Contents

Summary	5
Introduction	7
Short history and technical background	9
<b>1. Dismantling and rebuilding of tiled stove no. 1</b>	<b>13</b>
1.1 Dismantling and documenting	15
1.2 Rebuilding	21
1.2.1 Materials used	21
1.2.2 Cleaning of old building materials	23
1.2.3 Some secrets of the craft	27
1.2.4 Hands-on work	31
<b>2. Dismantling and rebuilding of tiled stove no. 2</b>	<b>57</b>
2.1 Dismantling and documenting	60
2.2 Rebuilding	73
2.2.1 Drawings of horizontal sections	105
<b>Appendix</b>	<b>119</b>
Course Programme 28.8.–3.9.2011 in Ekenäs, Finland	119
<b>About Gotland University</b>	<b>120</b>
<b>About Estonian Academy of Arts</b>	<b>122</b>

## Summary

This report is a step by step description of the dismantling and rebuilding of two very tall tiled stoves in an historic school building in Ekenäs, Finland. It is meant to serve as a guide to anybody who is interested in building or rebuilding a classical stove.

At the same time this is a report of the hands-on work performed by students from University of Applied Sciences Novia in Finland, Gotland University in Sweden and Estonian Academy of Arts in Estonia during the intensive course *Tiled Stoves* which was held in Ekenäs in September 2011. This was the third course within the joint project Sustainable Heritage, which is financed by the Nordic Council of Ministers through Nordplus stipends.

*The Sustainable Heritage project*, together with its follow-up *Traditional Wooden and Masonry Structures in the Baltic Sea Region* are presented through image galleries, professional reports and introductions to past and future courses on the Internet at the address [www.sustainableheritage.fi](http://www.sustainableheritage.fi)

Tiled stoves have been an integral part of all inhabited rooms around the Baltic Sea ever since the 18<sup>th</sup> century, when the apparatus was first invented or publicized by Carl Johan Cronstedt and Fabian Wrede, until the 1920's when central heating technique started to replace the old methods.

Today tiled stoves are in fashion again but there are few masons who are familiar with the secrets of the craft of building them. This report gives an idea of the many complicated elements in the work while it describes principles, details, tools and materials that are needed. Please, note that the masonry work is highly specialized and should never be undertaken by dilettantes for the obvious risk of fire. The presented documentation through photographs and measured drawings serve as a good example for similar work within the field of building conservation.



## Introduction

In your hands you have a documentation of the process of dismantling and rebuilding two historic tiled stoves. This report is meant to serve as a manual for anybody who is interested in building or rebuilding such a sustainable and most efficient heating apparatus. At the same time this is a dear memento for all those who took part in the described work.

The report is the result of very good cooperation between the 25 students of three nationalities, who gathered in Ekenäs, Finland, at Novia University of Applied Sciences, for the third intensive course in the *Sustainable Heritage* project. The international project is financed by the Nordic Council of Ministers through Nordplus funds. The three partner schools, Estonian Academy of Arts, Gotland University in Sweden and Novia University of Applied Sciences in Finland take turns in organizing and hosting these annual events. Know-how in the field of conservation is spread through practical exercises which are taught by expert craftsmen. Academic lectures, excursions and other activities are designed to promote cooperation and exchange of ideas between the participants. Each course is a unique experience in terms of learning about conservation in general and neighbouring nationalities with their traditions in particular. The meeting of building and painting conservators with construction engineers and site managers is also of great value since we all need to cooperate and respect each other's disciplines in order to maintain our built heritage.

This report describes the dismantling and rebuilding of two very tall tiled stoves in a school building that was constructed in 1871. There are two stoves in each of the classrooms, two in the hall and several in the corridor and auxiliary spaces; 15 are still standing although they have not been used since the installation of central heating in the 1960's. The class rooms have been in use until today. Apart from lighting fixtures, a colour scheme from the 1960's and modern furniture, the spaces have the century old atmosphere. The restoration of the stoves adds to the very special quality of the building; now students can enjoy a fire and the friendly warmth of the stoves at least in one of the class rooms while they are studying. We hope this will inspire the proprietors to further restoration instead of ruthless modernisation.



The first part of each report is the product of Finnish students of construction engineering and site management. They dismantled and documented the two stoves in spring 2011 and thus made the site ready for the Sustainable Heritage course in the following autumn. The rebuilding technique was mainly documented by Estonian and Swedish students with the help of the Finns who were more familiar with CAD drawing.

We highly appreciate master mason Krister Lindroos for sharing his know-how of tiled stoves and masonry in general while giving expert tuition of the hands-on work. Prof. Joakim Hansson, Kristin Balksten, Ulrika Mebus and Artur Ümar each contributed with their academic and practical interest and knowledge of tiled stoves in their native countries. Indeed, we had the opportunity to learn from some of the very best specialists on tiled stoves in the Baltic Sea region.

Thank you all!

Kirsti Horn, Senior lecturer, Architect SAFA, AA Dipl., together with students from the three partner universities.



*Hands-On in Ekenäs, September 2011: teaching staff in the first row from left, Krista Laido, Prof. Joakim Hansson, Atur Ümar (behind Joakim), Towe Andersson, Kirsti Horn, and to the far right Niklas R. Nyman and Krister Lindroos.*

## Short history and technical background

In the Nordic countries it is of vital importance to be able to generate heat in an economic and hygienic way as the climate is so severe that a mere bonfire in the middle of the house or even a fire place cannot keep you warm and comfortable. The revolution in the development of stoves took place in the 18<sup>th</sup> century in Sweden. It had become apparent that the forests were getting thin in the vicinity of habitation and industry and that wasting the fuel in ineffective stoves had to be stopped.

The kind of tiled stove that is still in use in the countries around the Baltic Sea is said to have its origin in the Alps. In 1767, Carl Johan Cronstedt, an architect, and Fabian Wrede, a field marshal, published their solution to the alarming problem of diminishing forests: a very efficient and economic heating apparatus, the tiled stove. The revolutionary idea was to store the heat from the fire into the mass of the brickwork in the stove by leading the smoke up and down through long vertical channels before letting it out through the chimney. In addition, the opening of the furnace was made smaller than it is in a traditional fireplace. The opening was also provided with shutters to regulate oxygen take and consequently the speed of the burning process. Furthermore, the chimney is closed by a damper to avoid heat loss after the fire is burnt down. Already in the very first drawings by Cronstedt and Wrede even the need for ventilation was solved by adding an air duct into the system of channels of one of the models they presented.

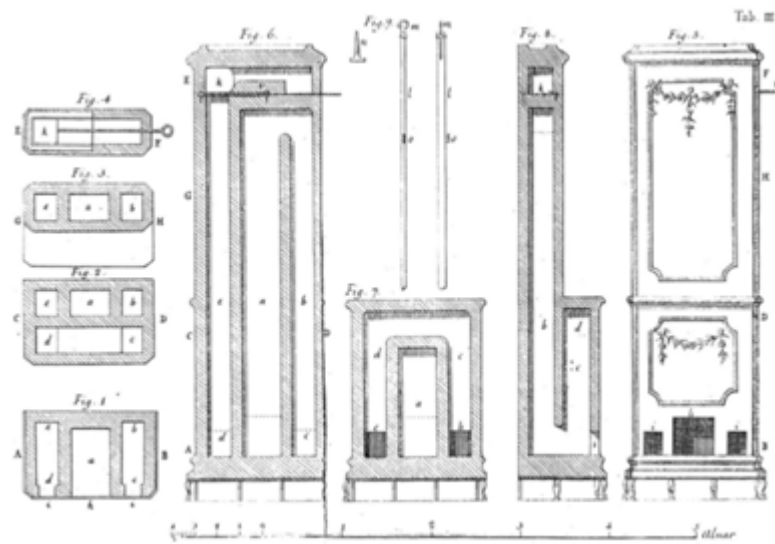


Figure 1. One of the drawings for a tiled stove by Cronstedt and Wrede 1767. (Margareta Cramér: Den verkliga kakelugnen).

The technical finesse of heating and ventilating has been solved in many different variations in the stoves of the past two centuries. Yet, the basic idea has not really changed. Modern stoves are made along the same principles as those in the times of the Enlightenment. In wealthy homes the stoves had traditionally a facing of glazed tiles while many vernacular houses had stoves of the same construction but finished with a thin render and lime wash. Stoves of one kind or another were the standard installation in practically every room until the 1920's when central heating technique started to replace the old methods. After World War II stoves were out for good, it seemed, and their production died out.

Lately the ideas of sustainability, energy saving and green building in general have brought the old methods in focus again. New stoves which work in the traditional way are in production and house builders have returned to the tradition not only in order to cut energy costs but also to create a cosy atmosphere. Antique tiled stoves that have

survived the changes of fashion give extra value to their surroundings. There is also a market for antique stove tiles because people who live in old flats or houses often want to recreate the original atmosphere by adding a period stove or two in the corner of their living spaces.

From the 18<sup>th</sup> until mid-19<sup>th</sup> century tiles were made locally by hand in potters' workshops. The industrial production started in the 1850's in Sweden and a few decades later in Finland. The design of stoves reflected the architecture and decorating styles of each period. The inside of stoves is built of red brick and clay mortar. It is important not to use cement in the mortar because this will break both tiles and bricks when the stove is dismantled.

*But why do we need to dismantle and rebuild a stove?* There are two technical reasons:

- If the foundations of the stove or the floor it stands on have given way the masonry will have cracked. This is obviously a most serious fire hazard which needs to be fixed.
- If a stove is heated daily for some 30–40 years the materials of its interior will finally break from the repeated heating and cooling; pieces of brick fall off and block channels, joints give way and bricks start to move etc. Also tiles often crack around the shutters where the thermal movement is greatest.

And, there is one cultural or historical reason, too:

- Since old tiled stoves are a valuable part of our built heritage they should never be destroyed. If a stove is not wanted it should always be dismantled with care and stored in sturdy boxes of wood until it is rebuilt again. Shutters and dampers and other metal components are a part of the design and ought to be stored together with the tiles.

In the rebuilding process it is tradition to reuse all good material from the old stove: tiles of course, but also shutters, dampers, strips of metal, nails and wire not to speak

of bricks and even mortar. Broken tiles were generally replaced but it was often impossible to find a matching colour. This is why old tiled stoves sometimes look like patch work. For instance one of the documented stoves has tiles of at least three different colours ranging from light blue to white. From this we can conclude it has been rebuilt at least twice if not several times. The broken tiles in our stoves were glued together instead of being replaced. After the joints and cracks are filled with a tinted plaster these disfigurements become almost invisible. Shutters, dampers, air vents, lids and all good bricks were reused.

In the following you can learn about the craft of restoring tiled stoves. The picture is completed by the slightly different approach in the two reports. Also we need to respect each mason and his particular method of constructing the smoke channels. You will notice that the inside of these stoves were not rebuilt exactly according to the previous stage. In this restoration job the objective was to put the stoves in working order and maintain their appearance. The students from Gotland University, Estonian Academy of Arts and Novia UAS succeeded with this in a most beautiful fashion although few of them had any previous experience of brick laying. This is, however, highly specialized work *and should never be done without close supervision of an experienced mason!*

#### Literature:

Tunander, B. och I.; Tunander P. (1999): *Svenska kakelugnar*.  
Stockholm, Nordiska museets förlag.

Mårtensson, H. (2001): *Husets hjärta, spisar i gamla hus*.  
Kalmar, Akantus edition.

Cramér, M. (1991): *Den verkliga kakelugnen*.  
Stockholms monografier 88.

Soiri–Snellman, H. (2003): *Turun kaakelin uunit*.  
Turun maakuntamuseon julkaisuja 3.

## 1. Dismantling and rebuilding of tiled stove no. 1

- Dismantling and documenting
- Rebuilding
- Materials used
- Cleaning of old building materials
- Some secrets of the craft
- Hands–on work

*Gotland University:* Fredrik Berg, Emelie Jansson, Lisa Johansson, Max Laserna, Isak Lind, Per Lindqvist, Maja Lofteskog, Niklas Martis, Frida Nordström, Elin Sahlin, Felix Thörnfeldt

*Estonian Academy of Arts:* Andres Muts, Kristiina Piirisild, Sille Siidirätsep, Maria Silla, Kaarel Truu, Pille Vilgota

*Novia University of Applied Sciences:* Jonas Gestranius, Tony Hagelberg, Tommy Helenius, Simon Jäkälä, Thomas Lindroos, Emil Lindström, Matias Loskin, Anton Öhberg, Anders Sjöström, Dennis Wilén





Figure 1.1. Tiled stove no. 1 in its original place and state.

1.1 DISMANTLING AND DOCUMENTING

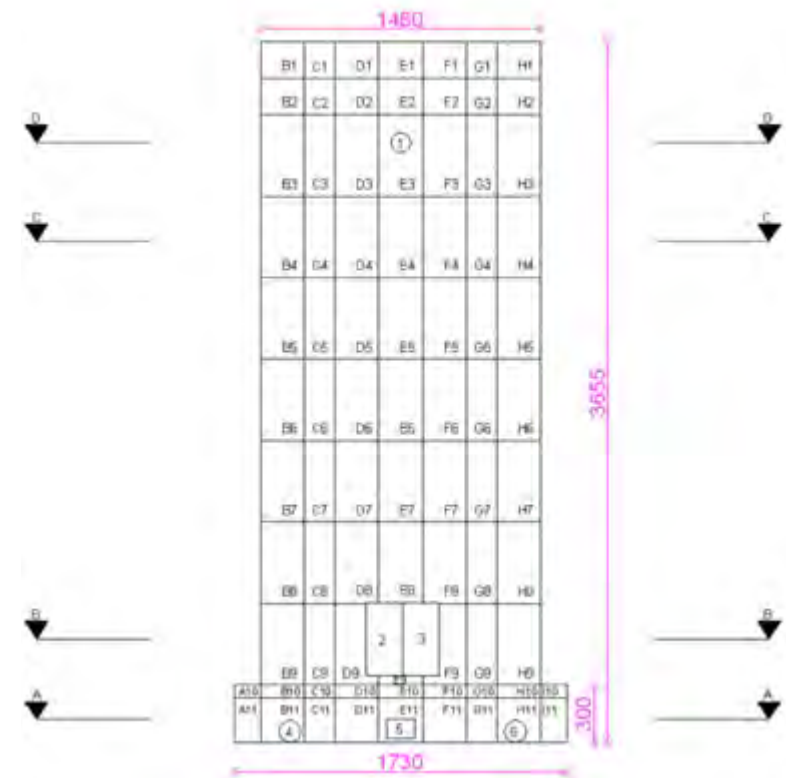
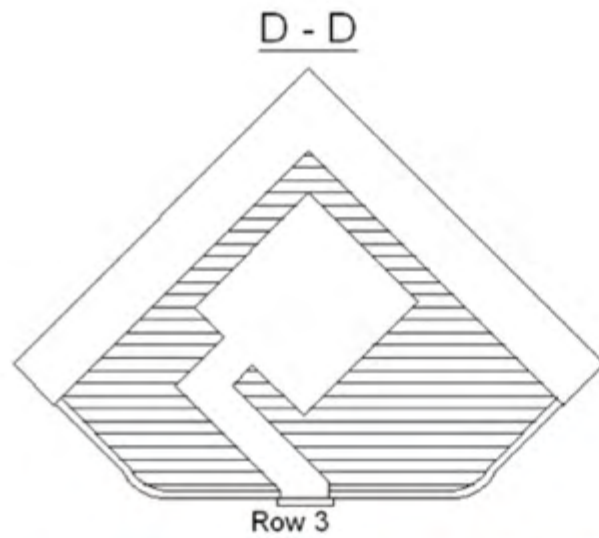


Figure 1.2. Coding system: a sketch of the tiles on the stove's front with codes for each tile.

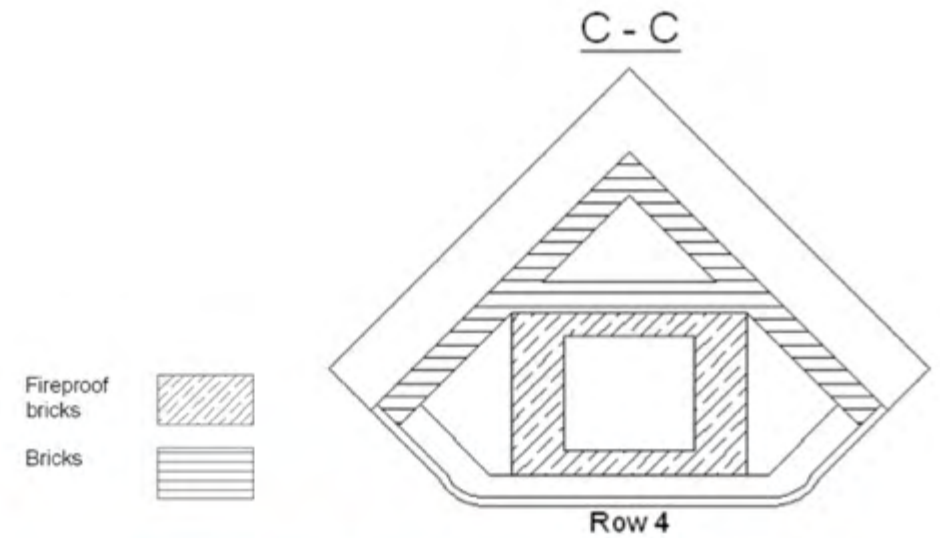
This tiled stove was originally situated in a small passage, and had not been used for a long time. After dismantling, we completely rebuilt it in the classroom next door.

We started by marking each tile according to the above coding system before the stove was dismantled. The dismantling was carried out starting from the top, working our way down. A, B, C and D indicate the sections we measured and documented.



Figures 1.3 a, b. Section D–D with air vent.

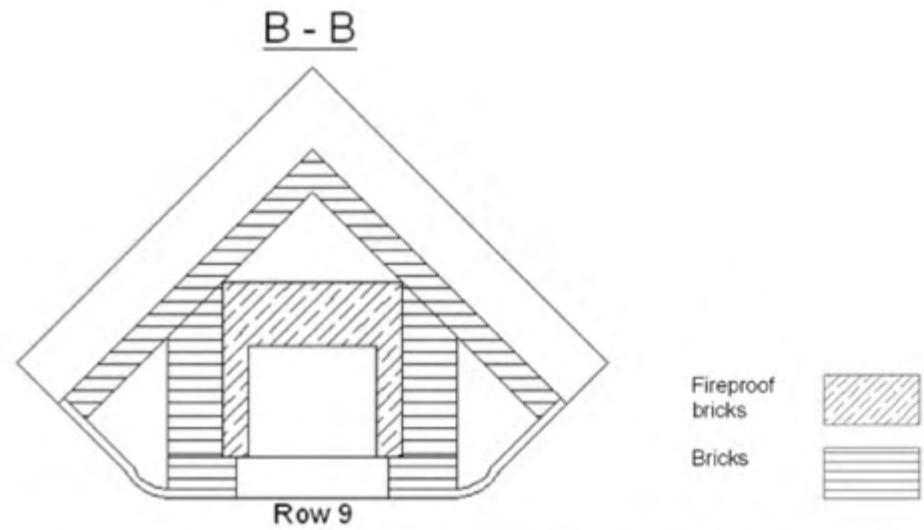
This drawing and photo show the first air vent we encountered in the dismantling process. It was situated behind row 3 of tiles.



Figures 1.4 a, b. Section C–C; image and technical drawing.

The photo shows a typical section of this stove. In the middle you can see the flue (up) from the furnace, and the secondary flues (down) around it. Tile rows 4–8 were all of this type.





Figures 1.5 a, b. Section B-B and photo of the same.

Here we see tile row 9 where the furnace and its doors were. The bricks closest to the furnace were all fireproof bricks.



Figures 1.6 a, b. Section A-A and image.

This picture shows the bottom row 11, where there was an ash dump and two openings for cleaning the flues. After we dismantled the last row of tiles we took apart the rest of the chimney and the back wall, which we had left there for stability.





Figure 1.7. It is important to keep all tiles in order so that the rebuilding will run smoothly.

## 1.2 REBUILDING

### 1.2.1 MATERIALS USED



Figure 1.8. Materials we used.

- Tiles (reused)
- Bricks: Thin red clay bricks (reused material) to fill the tiles (*left*); red clay bricks (reused material from the old stove) for building secondary flues (*middle*); fire-proof bricks (new) for building the furnace and the lower parts of the main flue (*right*)
- Ready-mix mortars and recipes: clay mortar, 25kg to 4–4,5 liters of water; fire-proof mortar, 25kg mixed with 4–4,5 liters of water
- Nails, wire and metal strip for connecting the rows of tiles
- Duct tape is used to secure the tiles during the assembly of the stove





Figure 1.9. Old bricks waiting to be cleaned and reused.

1.2.2 CLEANING OF OLD BUILDING MATERIALS



Figure 1.10. Cleaning the bricks is done by using a hammer and a trowel. Clay mortar comes off quite easily but the job is dusty and dirty.





*Figure 1.11.* The tiles were soaked in water to soften the mortar. Three rows of the tiles on the floor have been cleaned and the lower rows of tiles are already assembled on the stove.



*Figure 1.12.* Scraping off the mortar with a trowel.





*Figure 1.13.* Brushing off remaining particles of mortar. The manufacturer's stamp, ÅBO KFAB, stands for Åbo Kakelfabrik Ab, the Swedish for Turun Kaakelitehdas Oy.

1.2.3 SOME SECRETS OF THE CRAFT



*Figure 1.14.* A guillotine helps cutting the bricks with precision. The fireproof bricks in particular have to be cut to exact size because of the narrow joints in the furnace walls (1–2 millimeters).





Figure 1.15. A broken tile was fixed with wood glue. The pieces only need to be held together for the assembly—later the mortar joints will reinforce the tile.



Figure 1.16. Fireproof bricks and mortar are used for the furnace. The bricks have to cover each cross-joint of the previous course.



Figure 1.17. A spirit level should be used to level the bricks and help make the structure straight and secure.





Figure 1.18. A hammer is used to adjust the bricks and tighten the joints.



Figure 1.19. Washing off the clay mortar from the bricks in order to smoothen the walls of the flues.

1.2.4 HANDS-ON WORK



Figure 1.20. The base of the stove had already been built before we started.



*Figure 1.21.* The interior of the stove showing the floor of the furnace.



*Figure 1.22.* Laying the lower part of the furnace. Fireproof bricks and mortar were used. The masonry of the furnace should be bonded together with thin joints (1–2 mm) and separated from the rest of the masonry that has wider joints of clay mortar (13–15 mm).



*Figure 1.23.* The rear masonry was laid to the height of half of the next tiles to be used as a support for the tiles.

The next step was to build the smoke flue upwards from the furnace. It was made narrower than the furnace. The bricks were sawn sidelong to narrow the canal from 420 x 355mm to 350 x 160mm. This is always done to create draught through the stove. Further up the flue is made wider again.





*Figure 1.24.* Installing the second row of sawn bricks.



*Figure 1.25.* Continuing the laying of bricks at the rear. The gap between the fire wall and the rear masonry works as an insulator which keeps the warmth from transferring into the walls. It also allows the bricks to expand without breaking the stove.



*Figure 1.26.* Connecting the nails on top of the tiles to strengthen and stabilize the row of tiles.





Figure 1.27. Before placing tiles in the front the rear masonry is built up.



Figure 1.28. Corner tiles are the first to be installed. Therefore it is important to compare the distance between them with the width of the middle tiles. To keep the first tile in the right position and angle, it needs to be pressed downwards. A board with a weight is used. This is why the rear masonry needs to be built before the tiles are placed.



Figure 1.29. Installing the middle tiles on a bed of mortar.



Figure 1.30. Correcting the size of the tiles can be done either by filing or using an electric saw.



Figure 1.31. After making sure that the tiles are leveled they are secured with duct tape.





*Figure 1.32–33.* When the tiles are in place, the gap between them is filled with clay-mortar. Then two clamps made of perforated metal strap are bent to hold them together. The cavity on the backside of the tiles is then filled with mortar and thin bricks. Inside this a wall of bricks is built to finally stabilize the front.







Figure 1.34. The side gaps between the firewall and the tiles are finished with clay mortar. Behind this there is an air gap of some 3 cm.

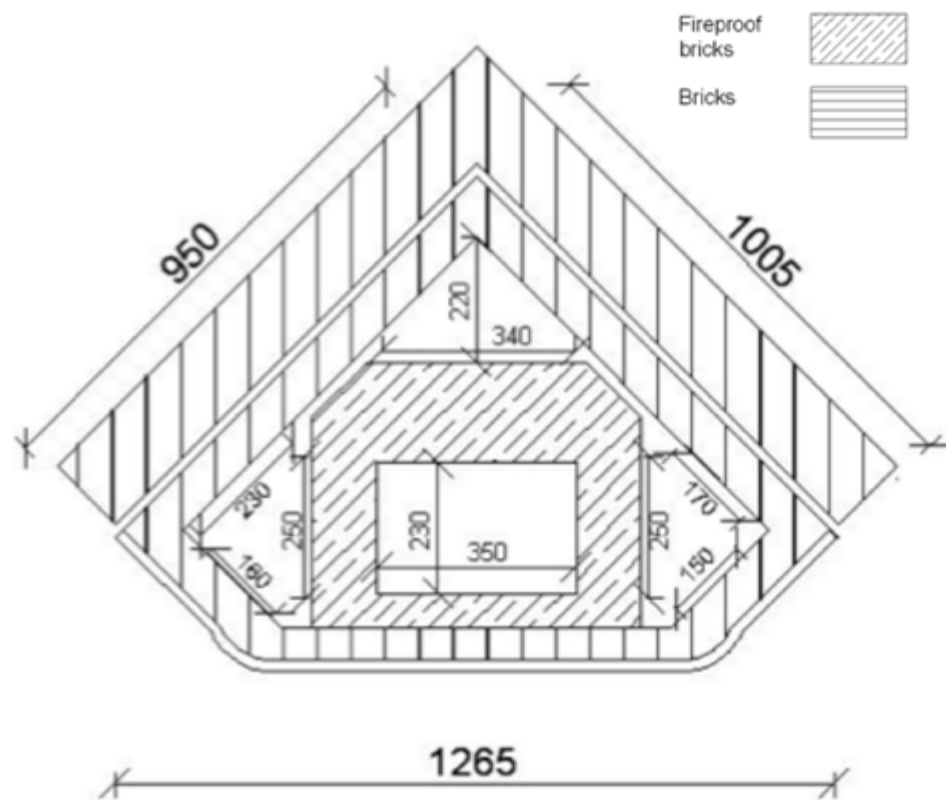


Figure 1.35. Interior of the stove at the end of day 1.



Figure 1.36. End of day 1. We had built our first row of tiles and the furnace behind it.





44

Figure 1.37. Measured drawing: section some 1000 mm above floor level. Regular bricks 265 x 125 x 75 mm; fireproof bricks 225 x 110 x 60 mm; tile and brick, thickness 75 mm.



Figure 1.38. Building the interior of the stove on day 2. The rows of bricks are also added over the shutters and all the way behind the tiles. There are no constructional changes from now on until finishing the central flue at the top.

45





Figure 1.39. End of day 2.



Figure 1.40. Five more rows of fire-proof bricks are layed up from the furnace. From then on the central flue is built using ordinary bricks and clay mortar.



Figure 1.41. End of day 3. One more row of tiles in place! Note the wire and how its ends are anchored into the joints of the back wall of the stove.





Figures 1.42–43. On day 4 two rows of tiles were installed.





Figure 1.44. Day 5. Finishing the central flue just before installation of the last row of flat tiles. The tops of the side walls of the central flue are rounded to direct the air-flow to the flue pipes.



Figure 1.45. Rosette air vent in the last row of tiles before installing cornice.



Figure 1.46. International meeting atop the scaffolding.





*Figures 1.47–48.* The chimney was repaired (*left*), before the crown tiles were finally inserted.





Figure 1.49. The face of the stove before joints and cracks were filled.



Figure 1.50. Final touches.





Figure 1.51. Rebuilding the stove was carefully documented.



Figure 1.52. Intensive international team work in a computer class room.

## 2. Dismantling and rebuilding of tiled stove no. 2

- Dismantling and documenting
- Rebuilding
- Drawings of horizontal sections

*Gotland University:* Fredrik Berg, Emelie Jansson, Lisa Johansson, Max Laserna, Isak Lind, Per Lindqvist, Maja Lofteskog, Niklas Martis, Frida Nordström, Elin Sahlin, Felix Thörnfeldt

*Estonian Academy of Arts:* Andres Muts, Kristiina Piirisild, Sille Siidirätsep, Maria Silla, Kaarel Truu, Pille Vilgota

*Novia University of Applied Sciences:* Jonas Gestranius, Simon Jäkälä, Tony Hagelberg, Tommy Helenius, Thomas Lindroos, Emil Lindström, Matias Loskin, Anton Öhberg, Anders Sjöström, Dennis Wilén

Sauna 16:15–20:00  
Novia stud. shows the way





Figure 2.1. Every kind of stove or fireplace has to stand secure and immobile since movements in the masonry would lead to cracks and obvious fire hazard. This enormous dry laid foundation supports the stove whose dismantling and consequent rebuilding is described in the following. The stove itself weighs several tons.

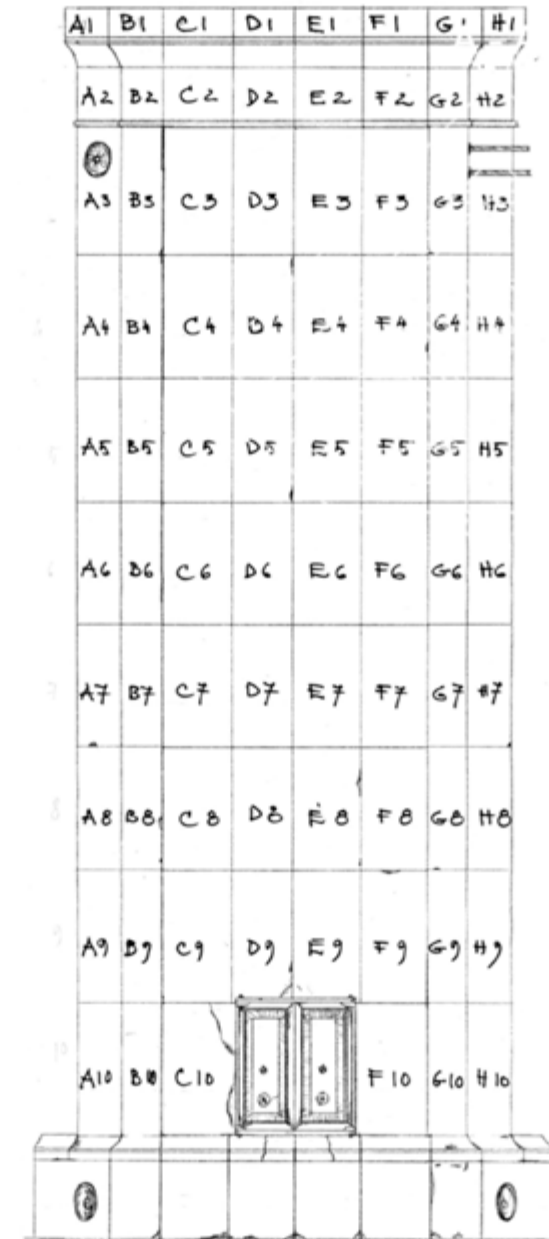
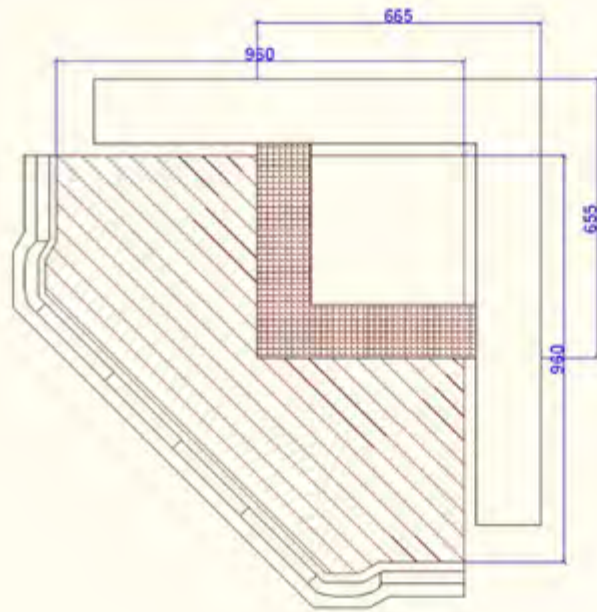
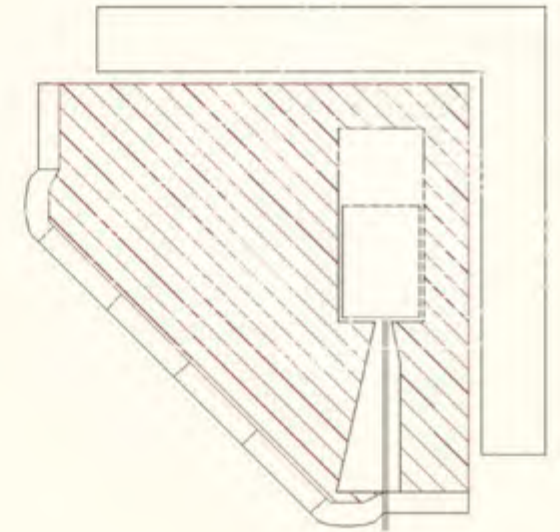


Figure 2.2. Measured drawing of the stove with a symbol for each tile. There are always slight variations in the measurements of tiles and therefore it is important to keep them in the same position when you rebuild the stove.

2.1 DISMANTLING AND DOCUMENTING

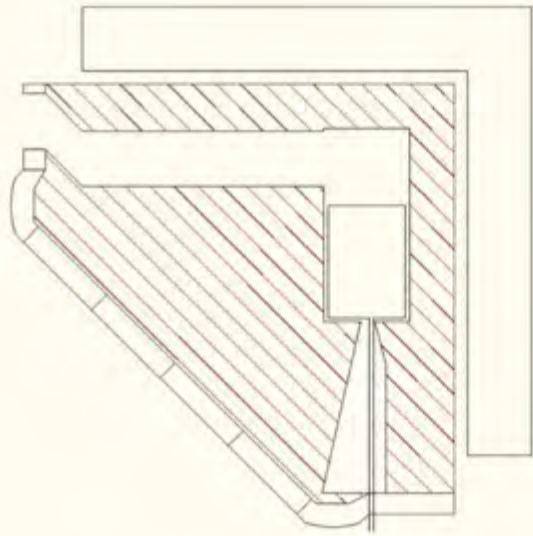


Figures 2.3 a, b. View of the top of the tiled stove before we began dismantling it. Above: a measured drawing of the same. Note the masonry fire walls that separate the stove from surrounding log constructions.



Figures 2.4 a, b. Two top rows of tiles have been removed and the top damper is now visible. Above: drawing of the same.





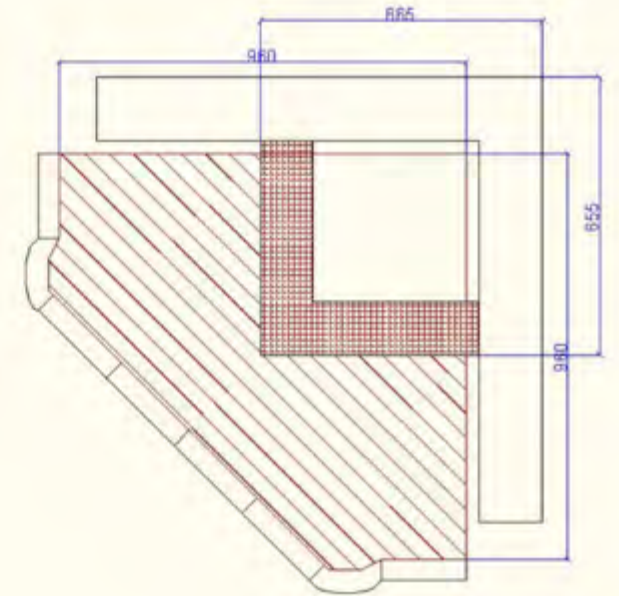
*Figures 2.5 a, b.* Top air duct was then revealed on the left hand side. Tiled stoves often have an air duct for ventilation in the summer months when the natural air conditioning through the furnace is not in use. This is why there are two dampers: in summer the bottom damper is closed so as to enhance the air flow through the vent into the chimney. When the stove is heated both dampers must be open and when the fire is down the top damper is closed in order to keep the heat from escaping. Also if you want to ventilate after heating you can close the bottom damper and open the top one. The warm chimney will accelerate the flow of air. Ingenious!

*Above:* drawing of the same.



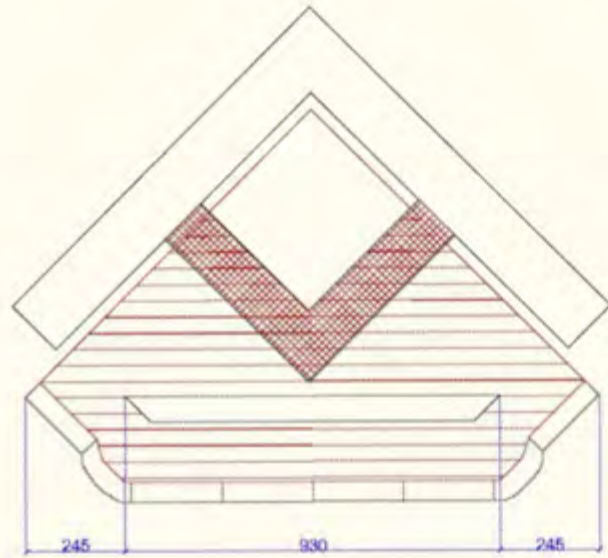


*Figure 2.6.* Three rows of tiles have been removed. A lot of water and patience are needed. You must never force your way because then the tiles will crack.

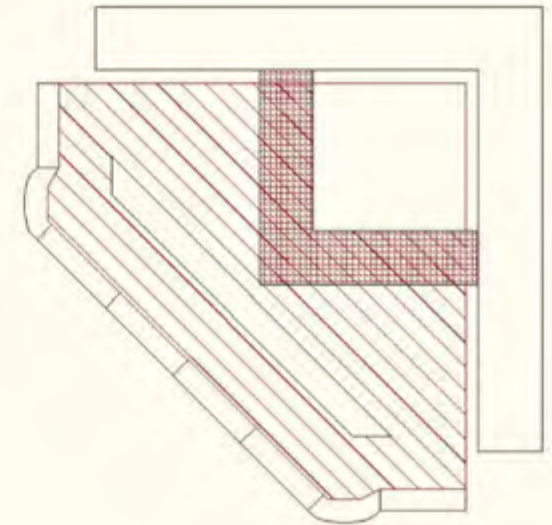


*Figures 2.7 a, b.* Top view of the fourth row of tiles. The brick work is still solid, i.e. none of the smoke flues that we were looking for are visible yet. *Above:* measured drawing of the same.

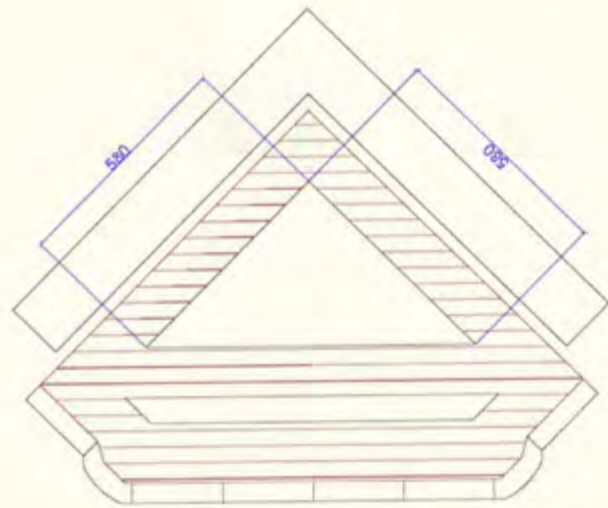




Figures 2.8 a, b. The smoke flue becomes visible two bricks down from the top of the fourth tile row. Above: measured drawing of the same.



Figures 2.9 a, b. The rear smoke flue which leads to the chimney is found at the top of the fifth tile row. Above: drawing of the same.

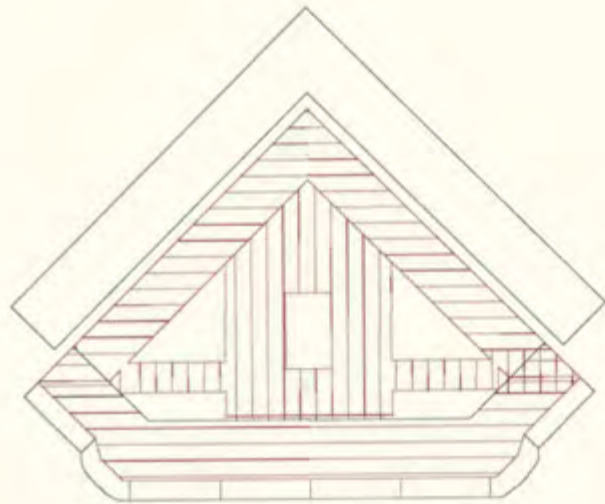


*Figures 2.10 a, b.* One row of bricks below the top of the fifth tile row: At last we can see the basic structure of the stove with its 5 flues. *Above:* measured drawing of the same.

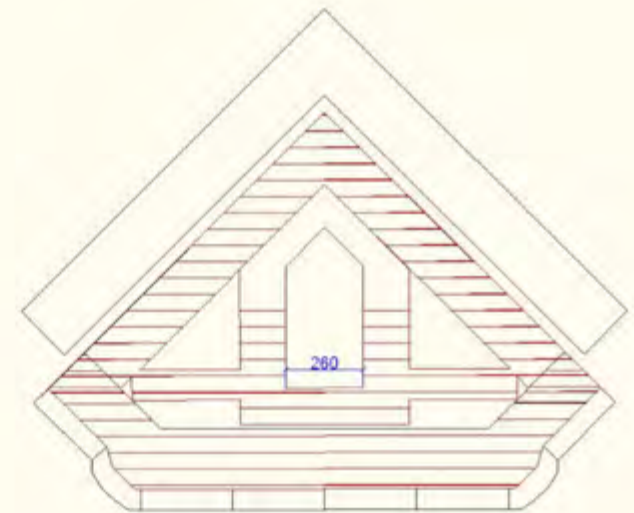


*Figures 2.11 a, b.* Three bricks down from the top of the fifth tile row: a clear view of the interior. *Above:* measured drawing of the same.

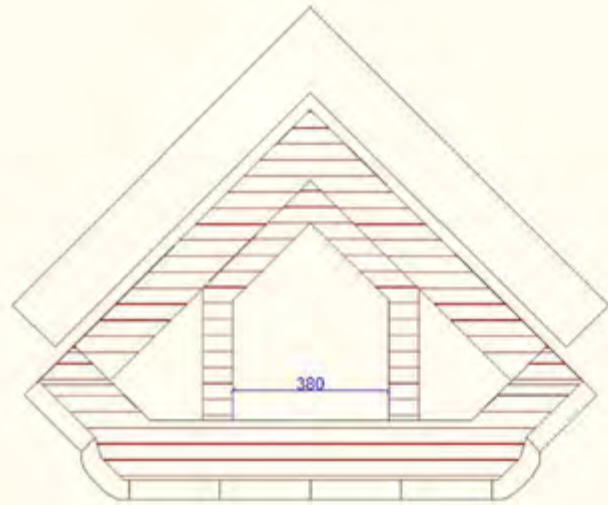




Figures 2.12 a, b. The sixth tile row, top view. This arrangement continued to row 9. Above: drawing of the same.



Figures 2.13 a, b. Top view of the ninth row of tiles. Here we can see the top of the furnace. Above: measured drawing of the same.



*Figures 2.14 a, b.* The ninth tile row is still in place but several rows of brick have been taken out from behind it. Here the floor of the furnace can be seen. This is where the dismantling was stopped because the bottom of the stove was intact and it was of course easier to start the rebuilding from a foundation that was of the correct size and shape. *Above:* measured drawing of the same.

## 2.2 REBUILDING



*Figure 2.15.* The tiles of the stove flat on the floor. All tiles are marked with identification numbers before the disassembly. Rows are marked with numbers, columns with letters.





*Figure 2.16.* Reusing old bricks is a must when maintaining our cultural heritage. Economizing with building materials is a sustainable approach which came naturally to our ancestors—why not us, too!



*Figure 2.17.* The rebuilding of the stove started with removing the mortar from the tiles and the thin bricks in the cavity on the back of each tile. The tiles are sunken in water for about half an hour in order to soften the old mortar before they are washed and cleaned. This is why it is important to use clay mortar: cement would not dissolve in water and the tiles would crack if they were cleaned with force.





*Figure 2.18.* The bricks, the metal clamps and mortar on the backside of the tiles are being removed. This takes time and you have to be patient because the edges and corners chip easily. Traditionally also the metal parts were reused but we ran out of time for that.

*Figure 2.19–20.* There is usually a stamp behind every industrially made tile. The stamp of SALON K.T.OY (Salon Kaakelitehdas Oy) was found on the back of some the tiles in this stove. This stove is a patchwork of tiles from several factories. It has most probably been taken down several times and each time the broken tiles have been replaced with new or recycled tiles. Salon Kaakelitehdas was owned by Turun Kaakelitehdas which was the largest producer of tiled stoves in the Nordic countries at the end of the 19<sup>th</sup> C. The model of this stove was one of the most popular ones through decades from the 1880's onwards.







*Figure 2.21.* This is where we started the rebuilding of the stove. The bottom two rows of tiles were already in place (they were intact and therefore not dismantled). Before laying new bricks the base had to be cleaned and the old mortar removed.



*Figure 2.22.* (A) The bricks are laid with clay mortar and with a 2 cm wide gap between the fire wall and the backside of the stove. (B) At the bottom of each side flue there is an opening with a metal cap. When the chimney (in the back corner of the stove) is swept the soot can be removed through these horizontal flues. The side cannels also join underneath the furnace floor and lead to the chimney in the back.



*Figure 2.23.* Aligning the tiles; you always start by placing the the corner tiles. A small plank with a weight is supporting the tile until the whole row is in place and all tiles can be connected, filled with mortar and bricks, and finally tied together with some wire.





Figure 2.24. A view from inside the stove shows how the tiles are set onto a bed of mortar.



Figure 2.25. The tiles are held together with metal clamps and mortar is then applied between the tiles.





Figure 2.26. The cavity behind each tile is filled with thin bricks and clay mortar.



Figure 2.27. Our first row of tiles, marked number 10, is in place. Tape is used to hold the tiles until the mortar has set.



Figure 2.28. One extra row of bricks is placed behind the tiles to give them support.





Figure 2.29. The cast iron frame with shutters is placed between the tiles.



Figure 2.30. The fireproof mortar is applied directly on the fireproof bricks before they are put in place.



Figure 2.31. Metal straps connected to the cast iron frame are placed in the joints of the brickwork. The furnace is being constructed.





*Figure 2.32.* The fireproof bricks are built to the upper part of the cast iron frame of the shutters.



*Figure 2.33.* The bricks and joints are being washed with a moist sponge.



*Figure 2.34.* The middle flue is narrowed at the back and front of the furnace with a row of bricks that have been shaped with an angle grinder. This bottle neck will improve the draught in the flue.



*Figure 2.35.* Side view of the top of the furnace.





88

*Figure 2.36.* Before using the angle grinder the fireproof bricks are hydrated to avoid over-heating the blade.



*Figure 2.37.* The rear wall and furnace are partially built before continuing to the next row of tiles. A plank is holding the bricks straight above the shutters until the mortar has set. The bricks are secured at each corner of the furnace into the masonry structure.

89





*Figure 2.38.* Nails are inserted into the existing holes in the flanges of each tile and tied together with a baling wire which is fastened in the joints of the rear brick course.



*Figure 2.39.* Nails and wire in detail.



*Figure 2.40.* The corner tiles of tile row 9 are aligned with spirit levels. A small amount of mortar is placed beneath them before they are put in place. Master mason Krister Lindroos (*in the front*) assists with the difficult parts.



*Figure 2.41.* When both corner-tiles are in place the distance is double-checked to insure that the centre tiles will fit.



*Figure 2.42.* The middle tiles are put in place and secured with duct tape. Three is a crowd.





Figure 2.43. When tile row 9 is in place it is time to lay the thin bricks in the flanges as described earlier. Once again the flanges are held together with metal clamps.



Figure 2.44. The rear brick wall and the front course is laid.



Figure 2.45. The baling wire is attached to the new nails.





Figure 2.46. The bottle neck forms a shelf above the furnace.



96

Figure 2.47. Behind tile row 8 the angle of the bottle neck of the middle flue has to be compensated in depth with approximately 50 mm of brick.



Figure 2.48. When tile row 8 had been laid a scaffold became necessary.

97





98 *Figure 2.49.* Tile row 6 was laid in accordance to the previous, and the arrangement of the interior did not change until tile row 4.



*Figure 2.50.* A view down the inside of the stove from the level of tile row 6.



*Figure 2.51.* When we reached the top of tile row 7, we ran out of old bricks and started to use new PT-standard bricks.



*Figure 2.52.* PT stands for 'peruskokoinen täystili', i.e. standard size solid brick of the dimensions 257 x 123 x 57 mm according to the producer (Wienerberger).



*Figure 2.53.* One and a half courses of the new bricks were laid. Before continuing the baling wire was attached as described before.



*Figure 2.54.* The wire is secured by a nail in the mortar joint of the side wall of the stove.





*Figure 2.55.* Looking down the system of flues just before the top was closed with solid brickwork.



*Figure 2.56.* It is important to clean the bottom of the smoke flues from mortar droppings before the mortar sets!



*Figure 2.57.* Tile row 3: the two dampers can be seen at the start of the chimney. To the left we have built the air duct for summer ventilation. (See also drawings.)



Figure 2.58. Crown tiles waiting to be installed.



Figure 2.59. The masonry work for the stove is finished when these wires are finally covered with bricks and mortar.

### 2.2.1 DRAWINGS OF HORIZONTAL SECTIONS

In the following the rebuilding of this stove is presented in drawings of horizontal sections. Every change in the shape of the masonry is presented. Numbers of tile rows relate to the coding presented earlier while letters describe layers of bricks behind the actual row of tiles.

We did not reconstruct all five flues as was the original design but opted for a simpler solution with one flue up, two down, and one up again. For beginners this was difficult enough!



Figure 2.60. View down the flues at the level of tile row 4 (see also drawing). The next row of bricks will close the front flues.



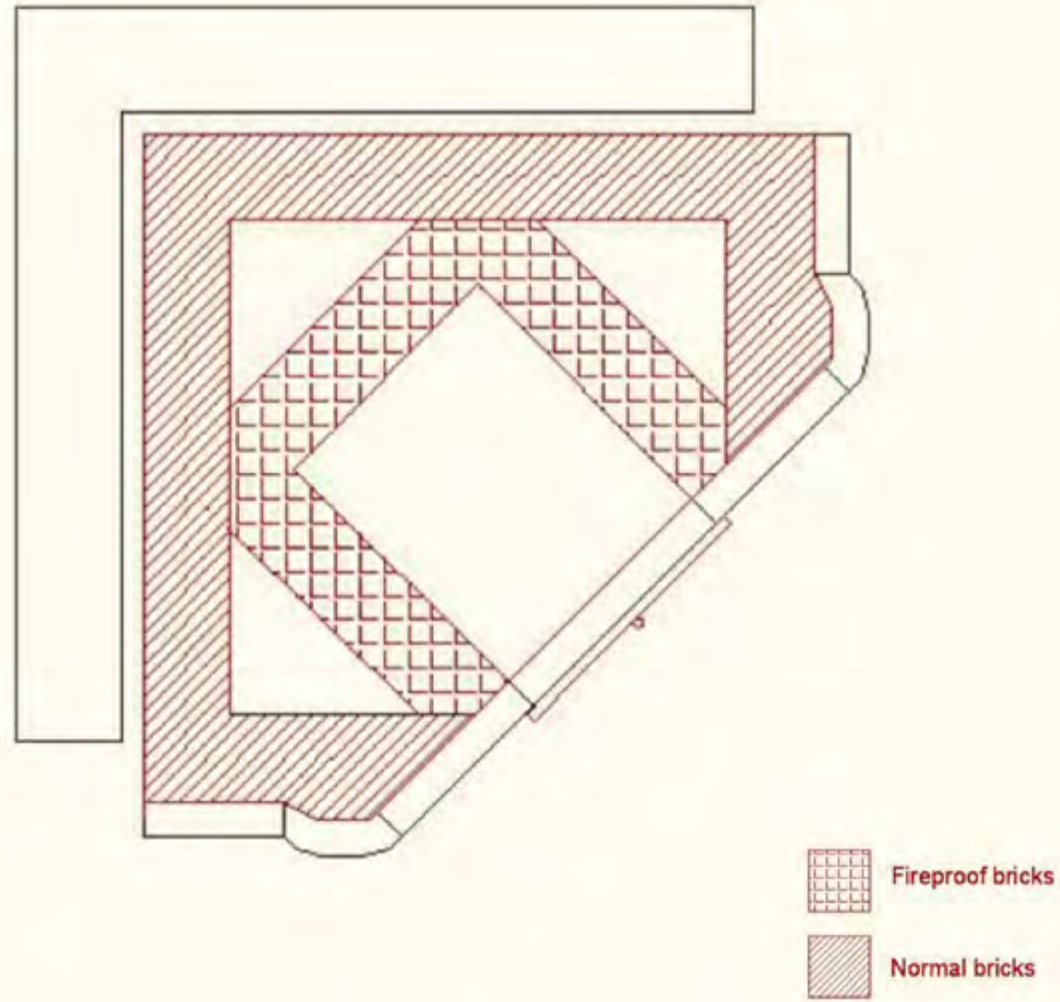


Figure 2.61. Tile row 10: square furnace in the middle; side flues meet underneath the furnace and lead to the flue in the back which leads to the chimney at the top.

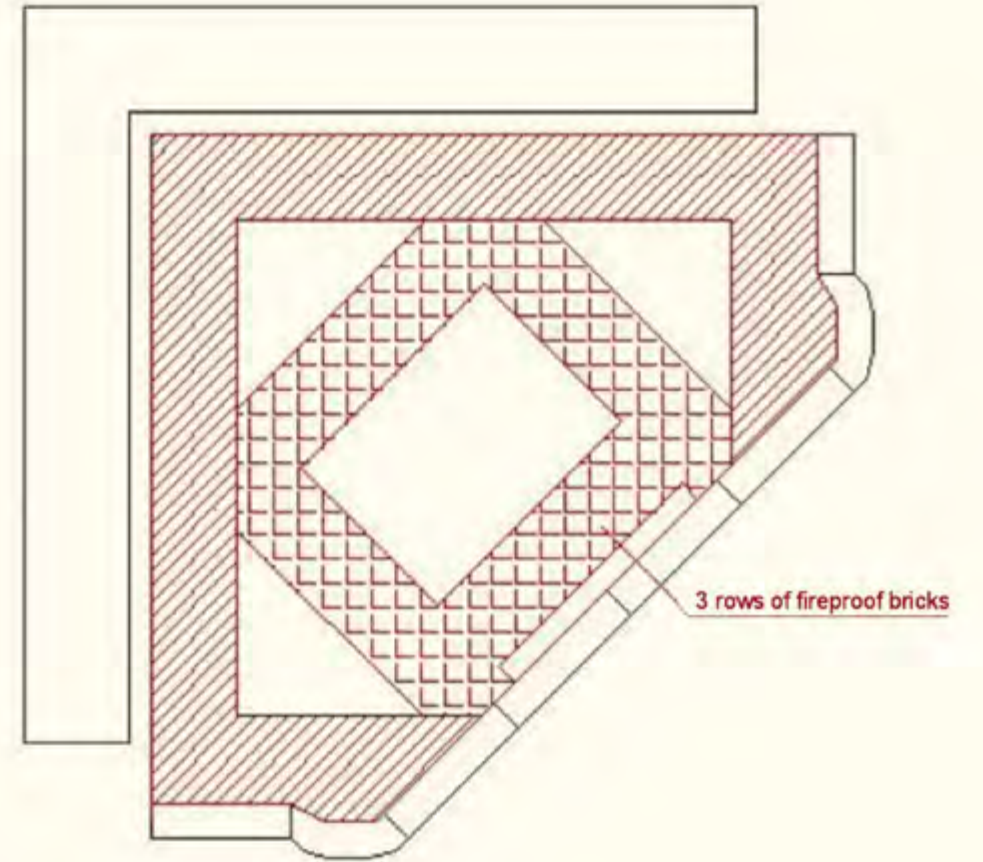


Figure 2.62. Tile row 9, brick row A.

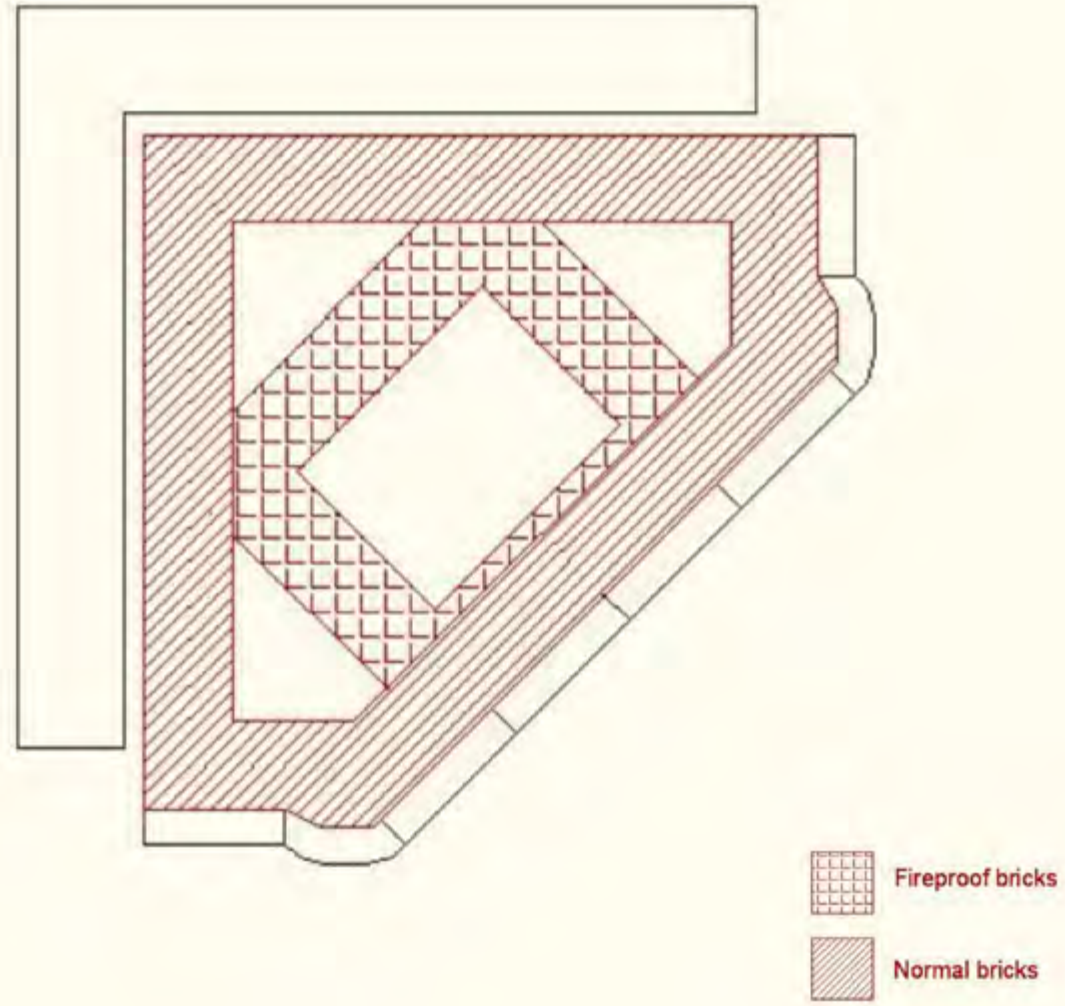


Figure 2.63. Tile row 9, brick row B.

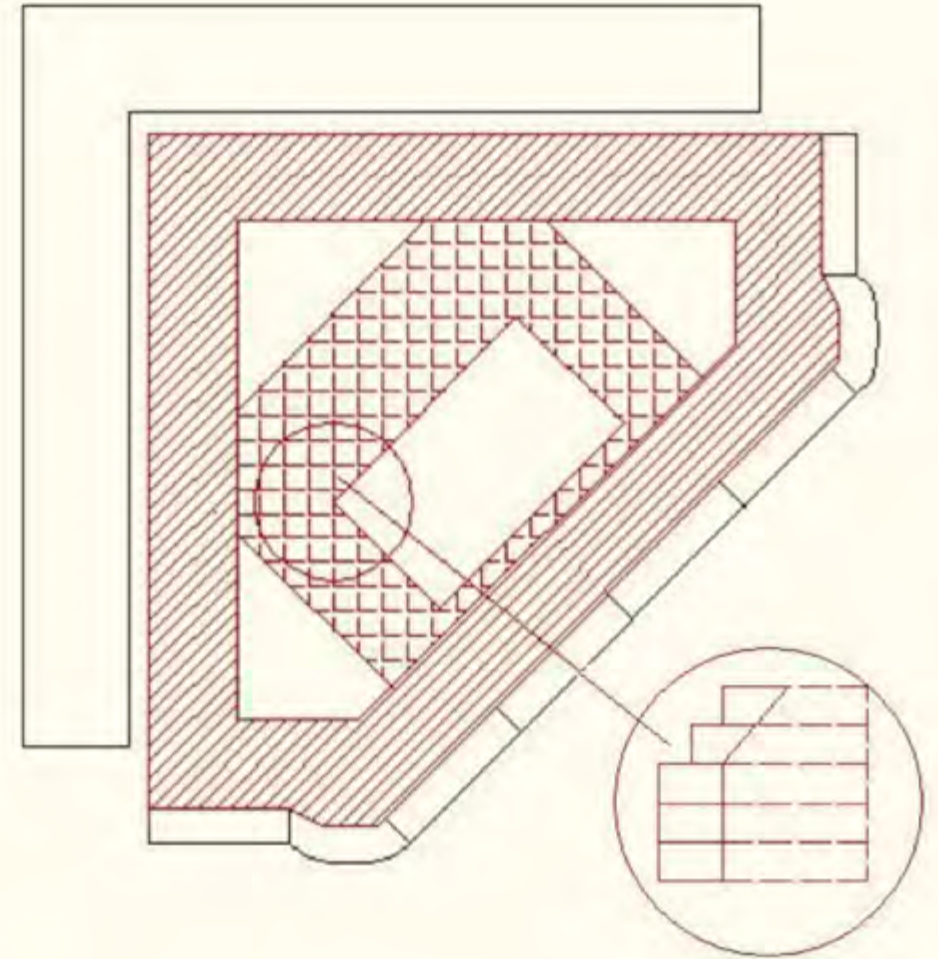


Figure 2.64. Tile row 8.



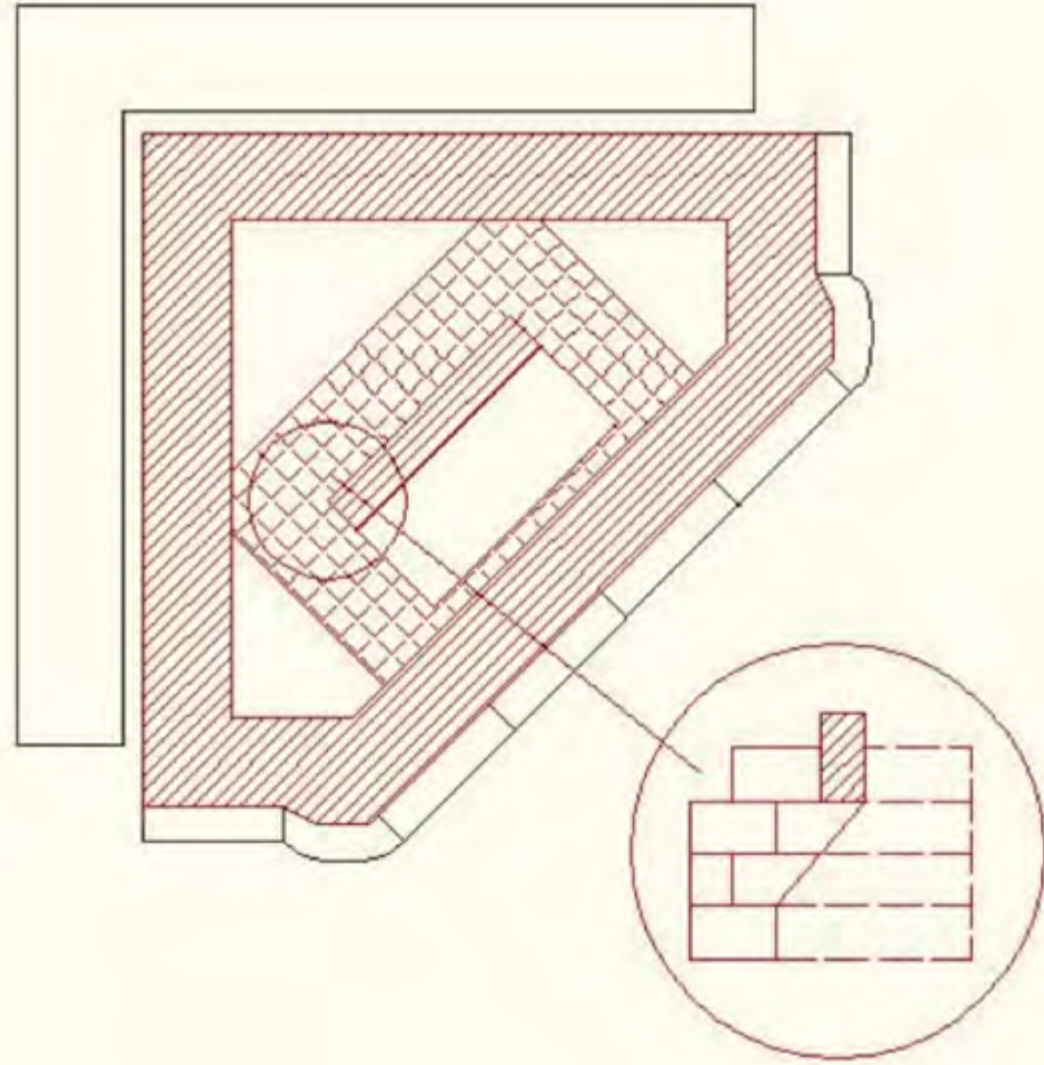


Figure 2.65. Tile row 7.

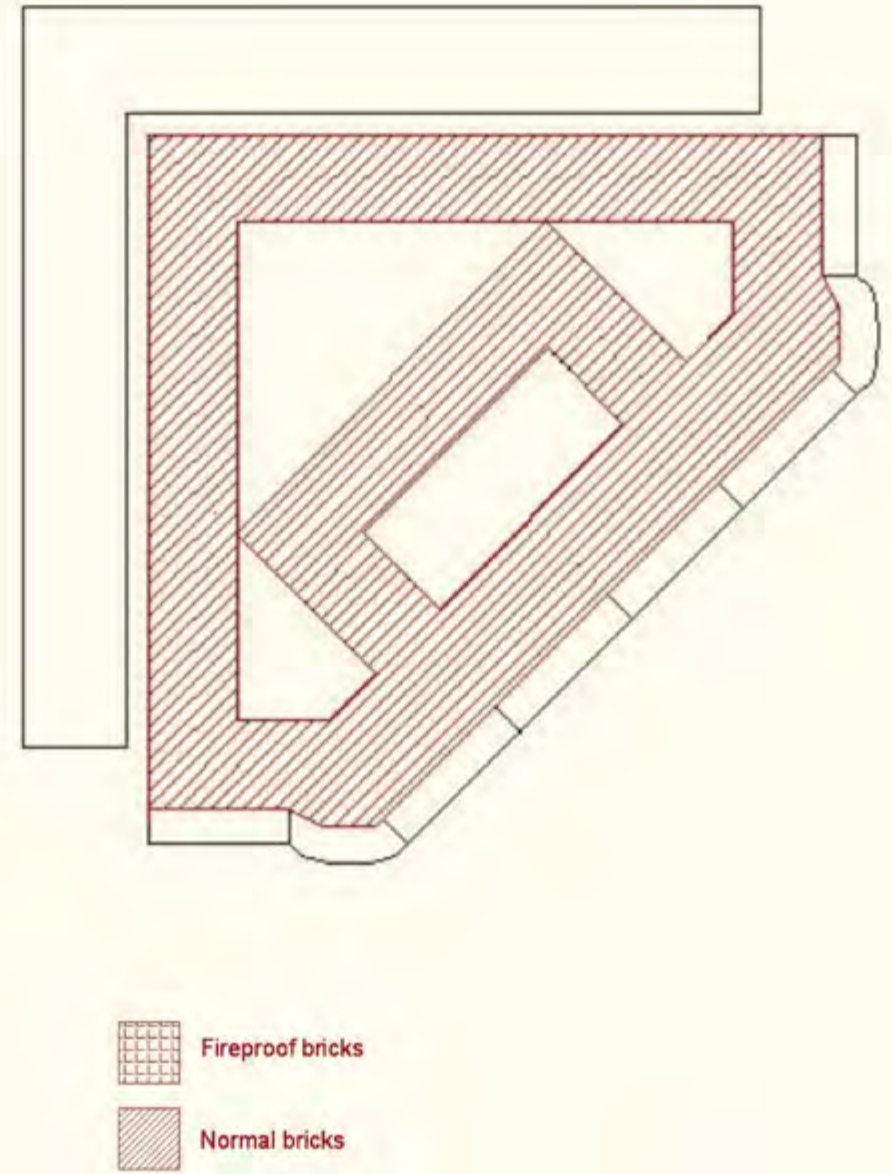


Figure 2.66. Tile rows 6 and 5.

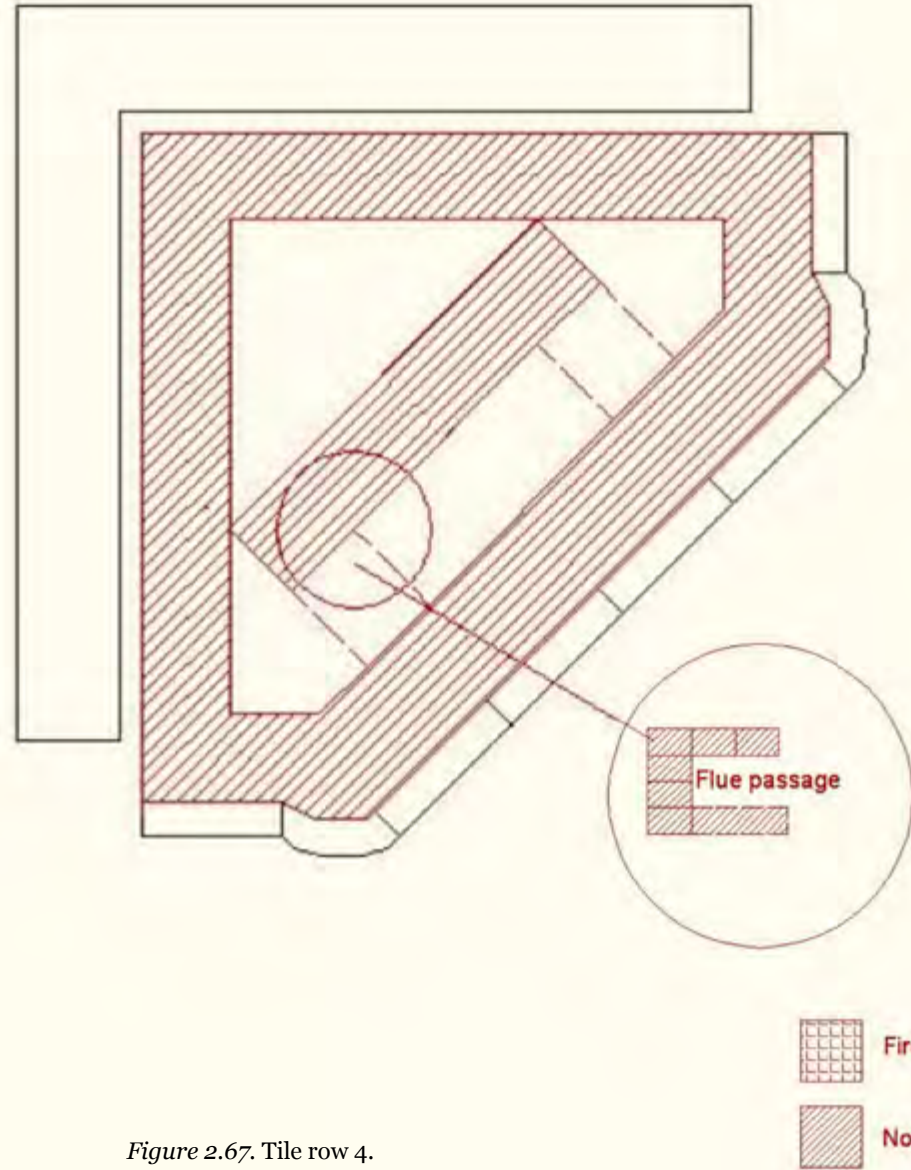


Figure 2.67. Tile row 4.

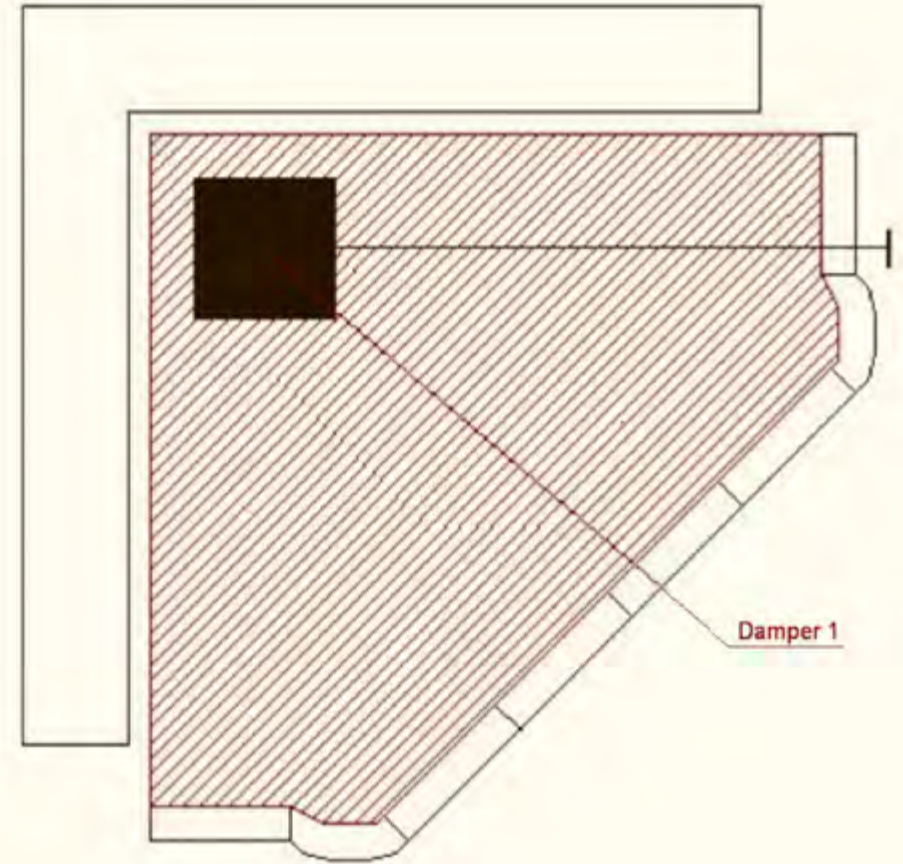


Figure 2.68. Tile row 3, brick row B: the top is closed by a layer of bricks below this level. Smoke from the furnace is lead down to the side flues. The chimney can be closed with a damper.



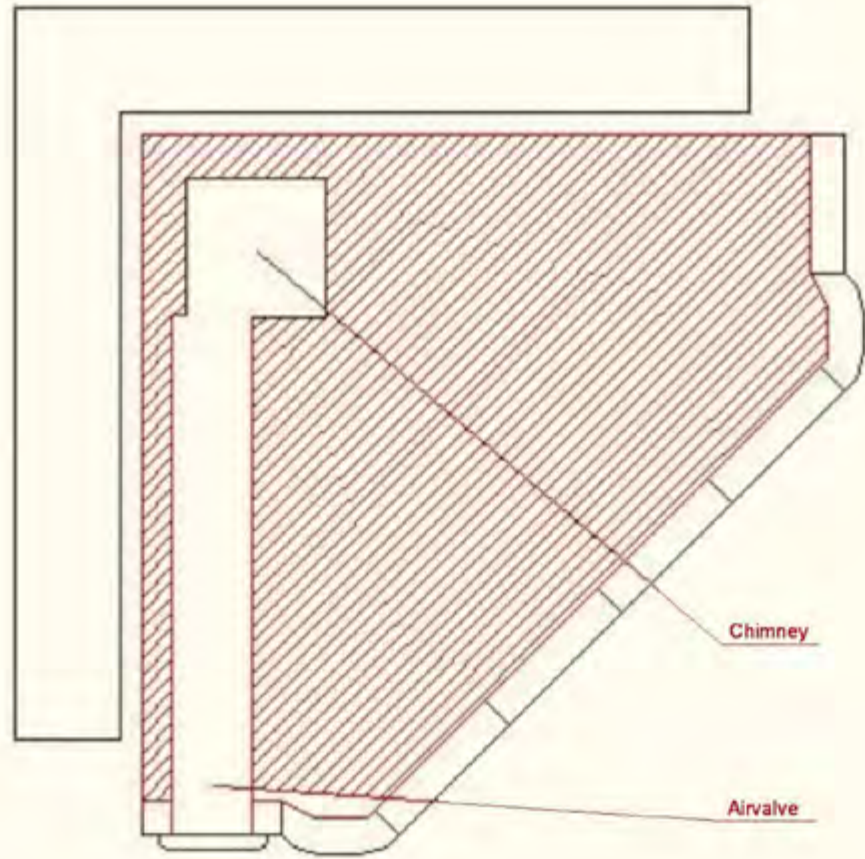


Figure 2.69. Tile row 3, brick row C: between the two dampers there is an air duct for ventilation.

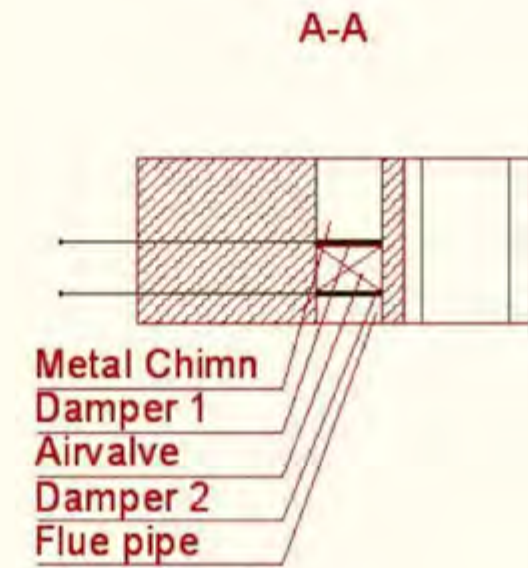


Figure 2.70. Section through air duct and chimney with dampers.

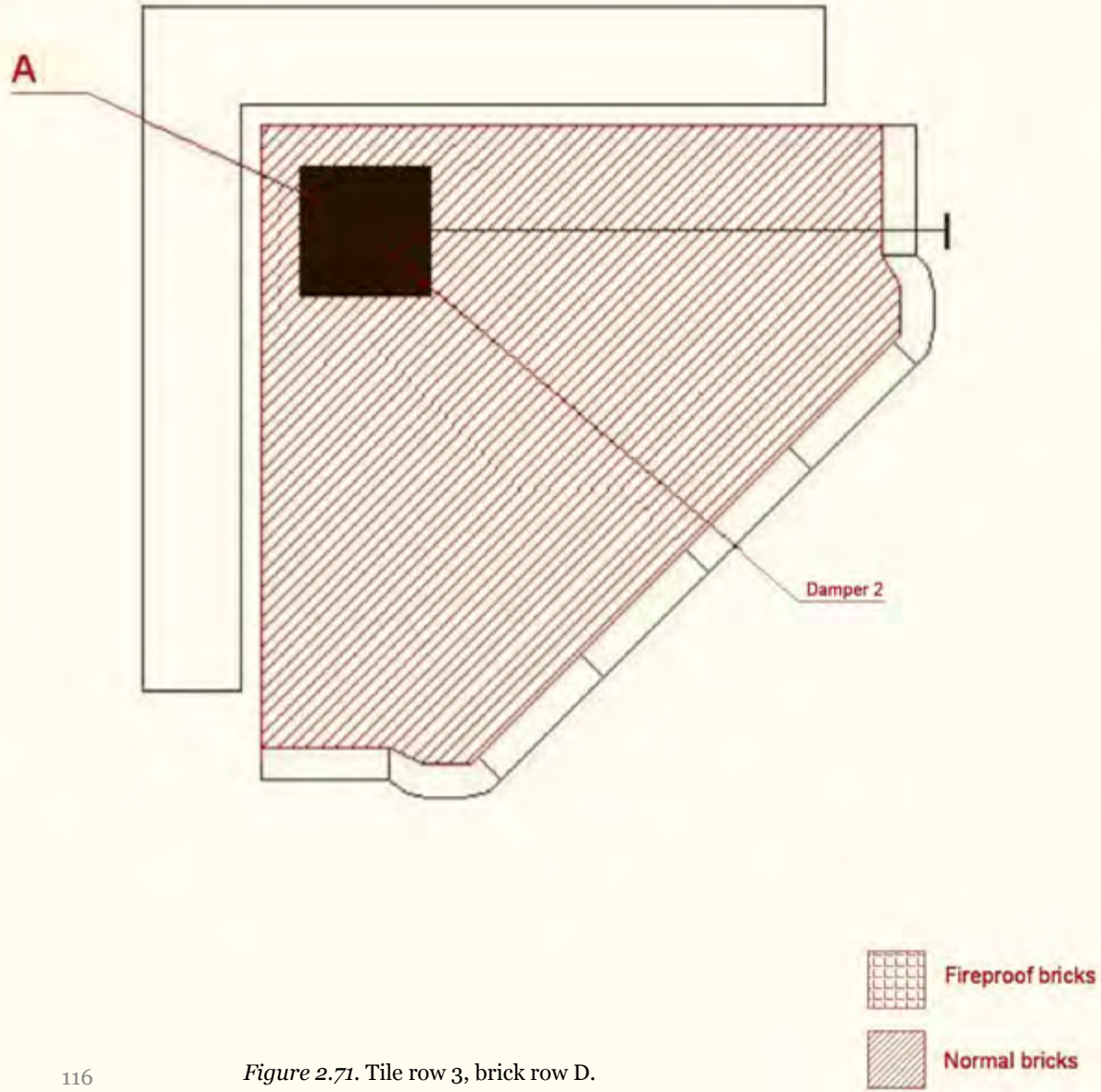


Figure 2.71. Tile row 3, brick row D.

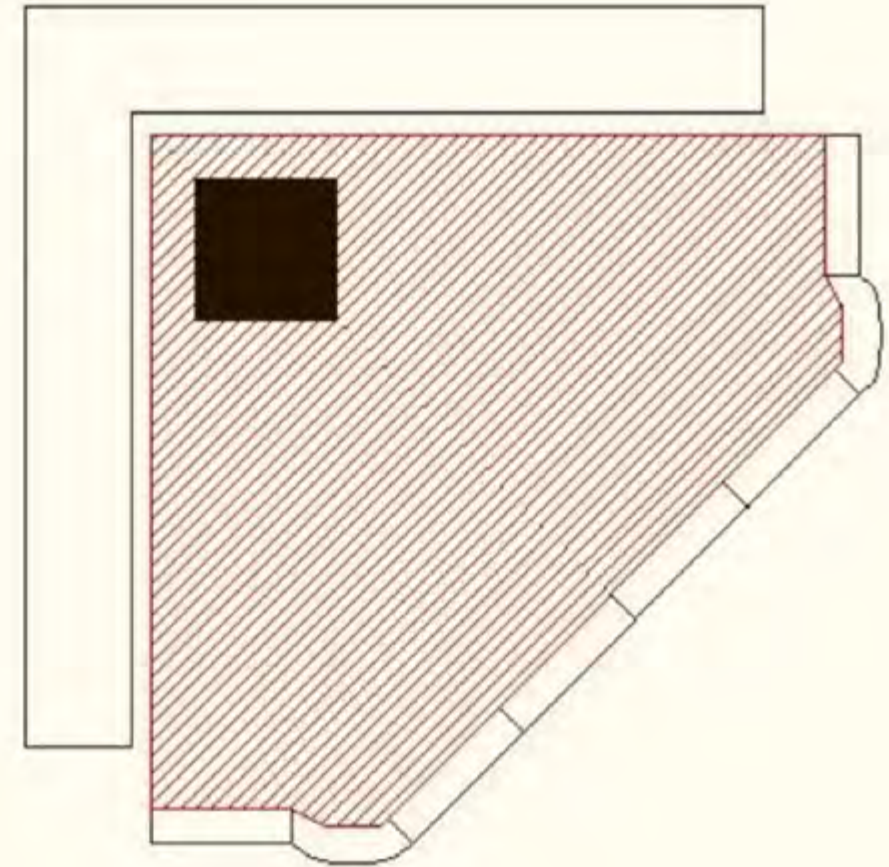


Figure 2.72. Frieze row.



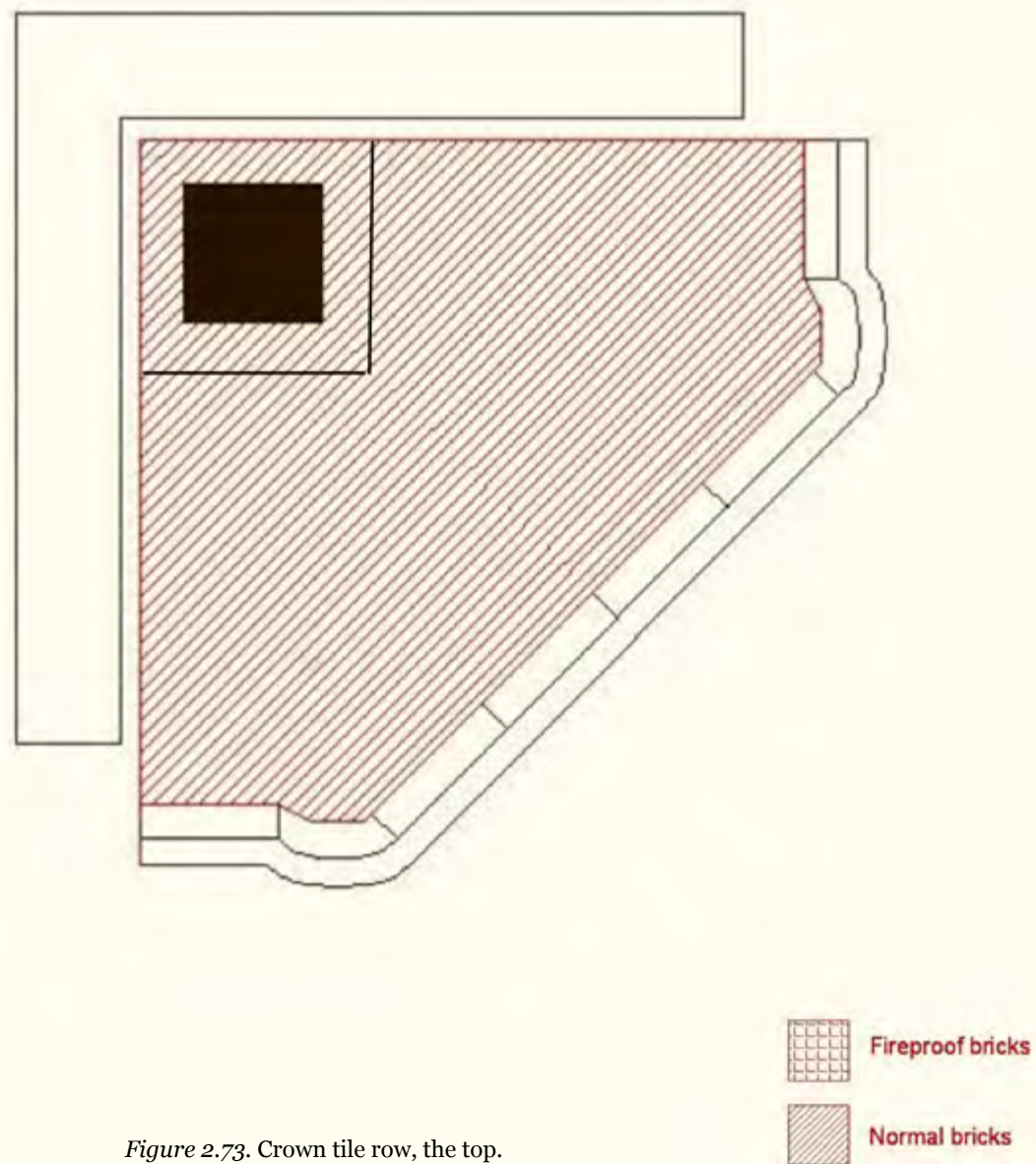


Figure 2.73. Crown tile row, the top.

## Appendix

## COURSE PROGRAMME 28.8.–3.9.2011 IN EKENÄS, FINLAND

Day 1 / Sunday, August 28, 2011					
Foreign students arrive before 16:00.					
Introduction and Welcome dinner for everybody.					
Hands-On Stove 1 and Stove 2	Group 1A / 2A	Group 1B / 2B	Group 1C / 2C	Group 1D / 2D	
Day 2 / Monday, August 29, 2011					
morning	Brick laying	Assisting work and documenting	Programme 1: lectures, excursion to local manors		1st row of tiles
lunch					2nd row of tiles
afternoon	Assisting work and documenting	Brick laying			3rd row of tiles
snack					4th row of tiles
evening	Sauna visit				
Day 3 / Tuesday, August 30, 2011					
morning	Programme 1: lectures, excursion to local manors	Brick laying	Assisting work and documenting		5th row of tiles
lunch					6th row of tiles
afternoon	Assisting work and documenting	Brick laying			7th row of tiles
snack					8th row of tiles
evening	Sauna; Report writing				
Day 4 / Wednesday, August 31, 2011					
morning	Assisting work and documenting	Brick laying	Programme 2: lectures, excursion to the archipelago		9th row of tiles
lunch					10th row of tiles
afternoon	Brick laying	Assisting work and documenting			11th row of tiles
snack					12th row of tiles
evening	Sauna				
Day 5 / Thursday, September 1, 2011					
morning	Programme 2: lectures, excursion to the archipelago	Assisting work and documenting	Brick laying		13th row of tiles
lunch					14th row of tiles
afternoon	Brick laying	Assisting work and documenting			15th row of tiles
snack					16th row of tiles
evening	Sauna				
Day 6 / Friday, September 2, 2011					
morning	Brick laying	Assisting work and documenting	Brick laying	Assisting work and documenting	17th row of tiles
lunch					18th row of tiles
afternoon	Assisting work and documenting	Brick laying	Assisting work and documenting	Brick laying	19th row of tiles
snack					20th row of tiles
evening	Sauna; Farewell party for everybody by the newly built stoves.				
Day 7 / Saturday, September 3, 2011					
Foreign students travel home.					

## About Gotland University

Gotland University was established in 1998 and is one of the youngest universities in Sweden. It is located in the World Heritage city of Visby on the island of Gotland, a geologically and ecologically unique island that is surrounded by the Baltic Sea. Gotland's rich historical past and beautiful natural environment attracts visitors from all over the world. These features as well as the many yearly cultural manifestations that take place all over the island create and enhance a stimulating learning environment for students and teachers alike. Gotland is a very dynamic region that favours education and actively promotes national and international exchanges and collaboration.

As the first university in Sweden, Gotland University has adopted a Liberal Education philosophy. Its mission is to prepare the student for personal growth and professional success while engaging him/her in today's complex world. Multidisciplinary teaching will achieve this. It implies that besides compulsory courses, the students can select courses according to their interest. For example, a student wishing to become a designer and who has a strong interest in ecology could choose from among courses in design and construction in combination with courses in ecology and biology.

All year around, quality 'on-campus' and 'internet-based' programmes and courses are offered in Swedish and English. The choice includes a Master Programme in International Management and independent courses in Archaeology, Osteo-Archaeology, Cross Cultural Studies, IT/Business Administration, International Business Relations, European Studies, Game Design, Building Conservation, Object Antiquarian Studies, Russian, History, Human Geography, Ethnology, Ecology and Art History.

Outstanding lecturers and international experts come to teach at Gotland University. Theory and practice are readily combined through participation in local businesses and regional affairs. Innovative thinking and a great sense of commitment are typical characteristics of both students and staff, which are reflected in our

academic and working philosophy.

Gotland University strives to promote quality in its many international exchanges and cooperation projects, and has been approved as an Erasmus University Charter institution by the European Union. Academic credits are translated according to ECTS (the European Credit Transfer System).



Gotland University / Högskolan på Gotland

Cramégatan 3

621 67 Visby, Sweden

Phone +46 498 29 99 00

Fax +46 498 29 99 62

[www.hgo.se](http://www.hgo.se)



## About Estonian Academy of Arts

Established in 1914, the Estonian Academy of Arts is the only public university in Estonia providing higher education in fine arts, design, architecture, media, visual studies, art culture, and conservation.

The EAA is striving to become a leading international centre of innovation in the field of visual culture. Currently there are more than 1 200 students enrolled in the Academy, with many participating in exchange programmes at international partner universities. In addition to active study and research activities, the Estonian Academy of Arts also offers lifelong learning opportunities through the Open Academy.

The Estonian Academy of Arts collaborates with more than a hundred universities worldwide and belongs to several international higher education networks.

The lecturers and instructors are professionals in their field—internationally recognised artists, architects, designers, historians, and scientists. Visiting lecturers from universities in Estonia and abroad are regular guests.

The Estonian Academy of Arts has a rich academic library that is constantly expanding its collection, a newly renovated joint dormitory with the Estonian Music and Theatre Academy, and training grounds at Tamse in Muhumaa and Heimtal in Viljandimaa. Departments of the EAA regularly organise student, faculty, and departmental exhibitions in various locations in Tallinn and elsewhere.

The EAA actively publishes different types of publications, including faculty members' books, textbooks, study materials, collections of articles, and advance reviewed works from the fields of art and science.

In 2010/2011, there are more than 600 students in the Bachelor's programme, close to 300 in Master's programme, 46 in the Doctoral programme, and close to 290 students in the Open Academy.

While offering a wide selection of specialities, the Academy also offers unique, individualised study and personal mentorship by members of the faculty. The departments are strong bodies of competence on their own, while at the same time facilitating synergy and interdisciplinary studies. Many faculties have been operating

for close to a century. They have lengthy experience and historical continuity, and also pioneer change in their field.

The Academy welcomes motivated people who are visually and socially sensitive and want to develop their thinking abilities, opportunities, and potential as creative people. The goal of the Academy is for graduates to be able to function successfully in society and work as independent creators and thinkers. That is why the curricula are formed in such a way as to develop the analytical ability and critical thinking of students. Every programme includes philosophy, history of art, aesthetics, and foreign languages.



Estonian Academy of Arts / Eesti Kunstiakadeemia

Estonia pst 7 / Teatri väljak 1

EE-10143 Tallinn, Estonia

Phone +372 626 7301

Fax +372 626 7350


E-mail [artun@artun.ee](mailto:artun@artun.ee)

EAA Skype: [kunstiakadeemia](https://www.skype.com/join/kunstiakadeemia)

[www.artun.ee](http://www.artun.ee)







*Through photographs and drawings this manual describes the work done on two historic tiled stoves in an historic school building in Ekenäs, Finland. It is meant to serve as a guide for anybody who is interested in building or rebuilding a tiled stove of the classical type.*

*The book is a product of joint efforts by students from Novia University of Applied Sciences in Finland, Estonian Academy of Arts in Estonia and Gotland University in Sweden who gathered in Ekenäs for an intensive course about tiled stoves.*

*Genom rikligt bildmaterial beskriver denna manual arbetet som utfördes på två höga kakelugnar i en historisk skolbyggnad i Ekenäs, Finland. Den är meningen att fungera som vägledning för dem som är intresserade i att bygga eller återbygga en traditionell kakelugn.*

*Boken är en produkt av gott samarbete mellan studeranden från Yrkehögskolan Novia i Raseborg, i Finland, Estonian Academy of Arts i Estland och Högskolan på Gotland i Sverige som samlades i Ekenäs för en intensivvecka om kakelugnar.*



ISSN: 1799-4209

ISBN (Online): 978-952-5839-43-2

YRKESHÖGSKOLAN  
**NOVIA**